

Incremental encoders

Solid shaft with EURO flange B10

300...5000 pulses per revolution

POG 9



POG 9

Technical data - electrical ratings

Voltage supply	9...30 VDC 5 VDC \pm 5 %
Consumption w/o load	\leq 100 mA
Pulses per revolution	300...5000
Phase shift	90° \pm 20°
Scan ratio	40...60 %
Reference signal	Zero pulse, width 90°
Sensing method	Optical
Output frequency	\leq 120 kHz \leq 300 kHz (on request)
Output signals	K1, K2, K0 + inverted Error output (only EMS)
Output stages	HTL-P (power linedriver) TTL/RS422
Interference immunity	EN 61000-6-2
Emitted interference	EN 61000-6-3
Approvals	CE, UL approval / E256710

Features

- Encoder with solid shaft \varnothing 11 mm
- Optical sensing method
- EURO flange B10
- Very high resistance to shock
- Output stage HTL or TTL
- TTL output driver for cable length up to 500 m

Optional

- Function control with EMS
(Enhanced Monitoring System)
- Second shaft end

Technical data - mechanical design

Size (flange)	\varnothing 115 mm
Shaft type	\varnothing 11 mm solid shaft
Shaft loading	\leq 250 N axial \leq 350 N radial
Flange	EURO flange B10
Protection DIN EN 60529	IP 56
Operating speed	\leq 12000 rpm (mechanical)
Operating torque typ.	2 Ncm
Rotor moment of inertia	200 gcm ²
Materials	Housing: aluminium die-cast Shaft: stainless steel
Operating temperature	-30...+100 °C -25...+100 °C (>3072 pulses per revolution)
Resistance	IEC 60068-2-6 Vibration 10 g, 10-2000 Hz IEC 60068-2-27 Shock 300 g, 1 ms
Explosion protection	II 3 G Ex nA IIC T4 Gc (gas) II 3 D Ex tc IIIB T135°C Dc (dust)
Connection	Terminal box
Weight approx.	1.4 kg

Subject to modification in technic and design. Errors and omissions excepted.

Incremental encoders

Solid shaft with EURO flange B10

300...5000 pulses per revolution

POG 9

Part number

Incremental encoder

POG9 **DN**

				Voltage supply / signals
			I	9...30 VDC / output circuit HTL with inverted signals
				TTL 5 VDC / output circuit TTL with inverted signals
			R	9...30 VDC / output circuit TTL with inverted signals
				<u>Pulse number - see table</u>
				<u>Output signals</u>
	DN			K1, K2, K0
				<u>EMS - Enhanced Monitoring System</u>
				Without EMS
			.2	With EMS

Pulse number

300	1000	2048	4096
500	1024	2500	5000
512	1200	3072	

Other pulse numbers on request.

Accessories

Connectors and cables

HEK 8 Sensor cable for encoders

Mounting accessories

K 35 Spring washer coupling
for solid shaft $\varnothing 6...12$ mm

K 50 Spring washer coupling
for solid shaft $\varnothing 11...16$ mm

K 60 Spring washer coupling
for solid shaft $\varnothing 11...22$ mm

Diagnostic accessories

HENQ 1100 Analyzer for encoders

Subject to modification in technic and design. Errors and omissions excepted.

Incremental encoders

Solid shaft with EURO flange B10

300...5000 pulses per revolution

POG 9

Output signals

At positive rotating direction

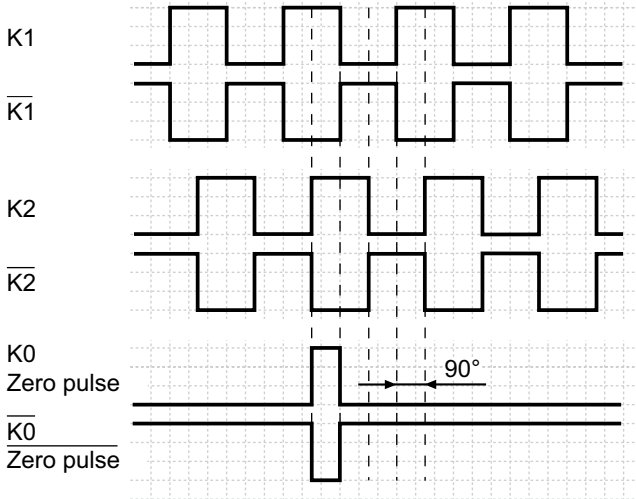

Terminal assignment

View A

Connecting terminal in terminal box

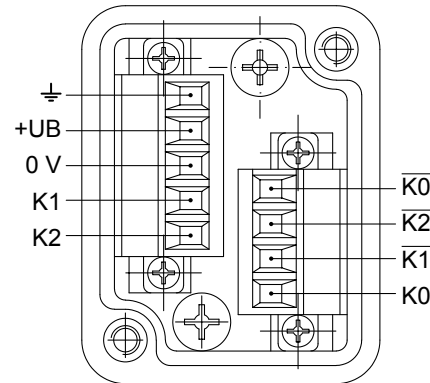

Option EMS: View A

Connecting terminal in terminal box

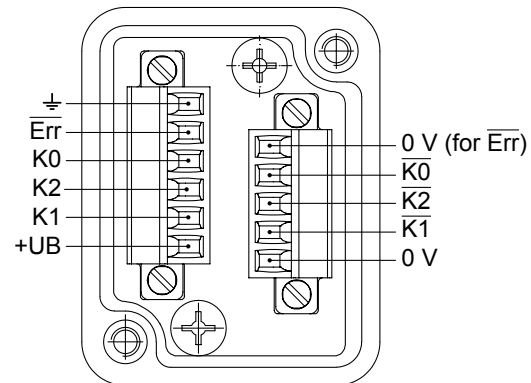

Option EMS: LED status / Error output

Flash light red*	Error of signal sequence, zero pulse or pulses (Error output = HIGH-LOW alternation)
Red	Overload output driver (Error output = LOW)
Flash light green	Encoder o.k., rotating (Error output = HIGH)
Green	Encoder o.k., stopped (Error output = HIGH)
No light	No output voltage connection or wrong connection (Error output = LOW)

* Only at rotating encoder

Incremental encoders

Solid shaft with EURO flange B10
300...5000 pulses per revolution

POG 9

Dimensions

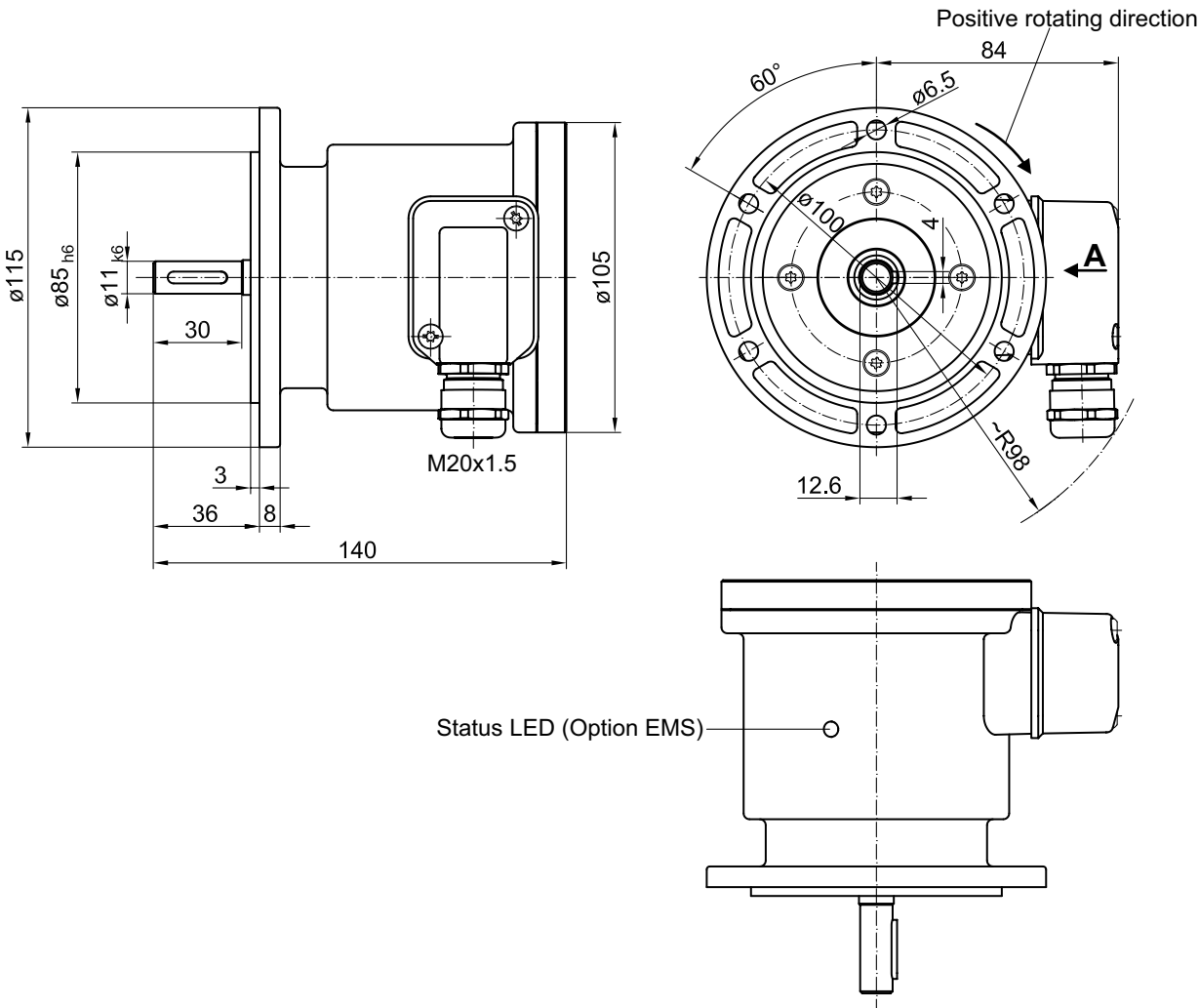

Subject to modification in technic and design. Errors and omissions excepted.